

DLS-VFT DOSING PUMP

A wall-mounted dosing pump with IP65 epoxy-coated aluminium enclosure



PB-VFT pump incorporates a microprocessor unit providing different operating modes:

MODE 1 - MANUAL: The pump dispenses at a set frequency which can be selected using the operator panel.

MODE 2 - MULTIPLIER (1x n/M): The pump unit receives a pulse from an external source (i.e. water meter) and supplies the number of injections indicated on the selector. In the instance where a second pulse is received before the pump unit has completed the cycle, the pump retains this external pulse within its memory and re-starts at the end of the completed cycle. This is particularly suited for high concentration dosing.

MODE 3 - MULTIPLIER (1xn): As MODE 2 but an external pulse received while carrying out a cycle is not retained within the memory but is ignored.

MODE 4 - DIVIDER (1:n): The pump supplies an injection when it has received the number of pulses set on the selector.

Technical Information

- Epoxy-coated aluminium housing
- IP65 rating
- PTFE diaphragm
- Polypropylene pump head (PVC for 05-20)
- Polypropylene filter & nipples
- Viton seals
- ON-OFF L.E.D. (green)
- Pulse L.E.D (red)
- Level L.E.D. (yellow)
- Function & pulse selectors
- 230/240V single phase

Accessories Included:

- 2m transparent PVC flexible suction hose
- 2m white Polyethylene discharge hose
- 1 Injection valve
- 1 Filter
- 1 Instruction Manual

PUMP MODELS:

MODEL	Max Flow l/hr	Max Press bar	Max Freq imp/min	ml per stroke	Stroke length mm	Suction m	Watts	kg
DLS-VFT 1-10	1	10	100	0.16	0.8	1.5	40	4.2
DLS-VFT 2-10	2	10	160	0.21	0.8	2	40	4.2
DLS-VFT 2-20	2	20	160	0.21	1.1	2	60	4.2
DLS-VFT 5-10	5	10	160	0.52	1	2	60	4.2
DLS-VFT 5-15	5	15	160	0.52	1.8	2	93	4.7
DLS-VFT 5-20	5	20	160	0.52	1.5	2	115	5.2
DLS-VFT 10-7	10	7	160	1.04	1.4	2	60	4.2
DLS-VFT 10-10	10	10	160	1.04	1.1	2	93	4.7
DLS-VFT 15-5	15	5	160	1.56	2.2	2	111	5.2
DLS-VFT 20-5	20	5	160	2.08	2.2	2	111	5.2
DLS-VFT 30-4	30	4	180	2.8	1.4	1.5	124	5.7
DLS-VFT 50-3	50	3	180	4.6	1.7	1.5	124	5.7
DLS-VFT 80-1	80	1	180	7.4	2.4	1.5	124	5.7

DIMENSIONS:

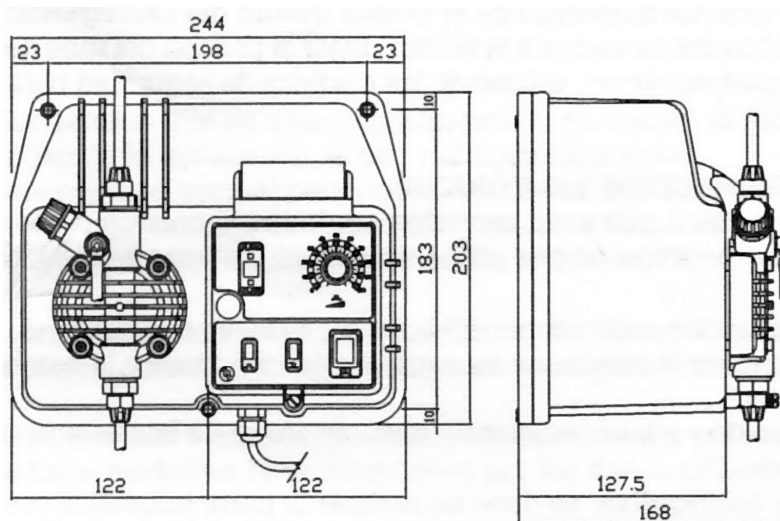

Water-purifiers.co.uk
 Penstar
 Rhoshill
 Cardigan
 SA43 2TX

Tel: 0845 129 7253
 Fax: 0870 746 8909

info@water-purifiers.co.uk
 www.water-purifiers.co.uk